



Open Scale Target Reading Type Level Indicator, 131

Open Scale Target Reading Type Level Indicator 131, is a level gauging device suitable for all types of non pressurized tanks like cone roof, flat roof, floating roof, underground tanks and tank in service etc.. The total unit consists of two types of parts, viz., wetted parts and non wetted parts. Wetted parts are the parts which come in contact with the liquid e.g. guide wire anchor, guide wires, float etc. Non wetted parts are the ones which do not come in contact with the liquid e.g. float cable, mounting brackets, indicator assembly and gauge boards etc. Option of Volume indication is also available.

SALIENT FEATURES

- Simple, low cost and reliable level gauge.
- Wetted parts available in SS304 / SS316.
- Suitable for installation on " tank in service ".
- Indicator rolls on the gauge board with the help of Nylon rollers.
- Can be used for the applications with volatile liquid or inert gas blanketing by using liquid seal assembly.
- Large numerals visible from a distance.
- Supplied with all hardware required for installation.
- Simple installation and commissioning.
- No maintenance required.

The Open Scale Target Reading Type Level Indicator, 131 works on the principle of buoyancy. The level sensing part in the unit (guided or unguided float) is connected to the counter weight (indicator assembly) through SS cable (float cable). The indicator assembly rolls on the gauge boards graduated in terms of level (Refer above figure). Gauge boards of suitable length are supplied with the unit. For installation of the unit, three sockets or flanged nozzles (two for guide wires and one for float cable), supports for the gauge boards and bottom anchor are required. If the tank is metallic, the bottom anchor is to be welded. If the tank is of RCC, the bottom anchor is grouted. For horizontal cylindrical tanks of measuring range upto 3000 mm, normally guide rod assembly (instead of guide wires) is recommended. This arrangement is also suitable for underground tanks where, float assembly can be taken out through man hole. This arrangement is shown in the figure 10 on page no. 3.

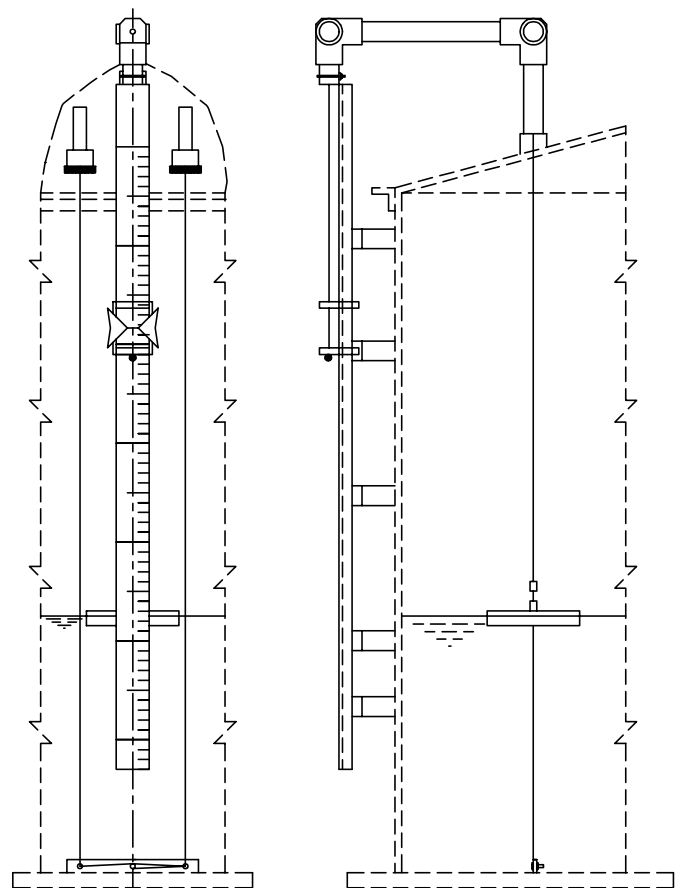

APPLICATION NOTES

- For tank height upto 4 meters, generally guide rod assembly is recommended.
- Liquid seal assembly is recommended for blanketed tanks or tanks with the volatile products (upto 600 mm WC).
- Checker assembly facilitates periodic testing of float for correct operation.
- Minimum two gauge boards are supplied (100 mm & 200 mm). Measuring range can be less than 100 mm also.

ORDERING CODE

1 3 1 - T

H = _____

TANK HEIGHT IN mm. ⁵

FUNCTION

- Level Indicator L
- Level + Volume Indicator V

MOUNTING ARRANGEMENT

- Side of the tank 1
- Top of the tank 7 2
- Top of the tank 8 3
- Side of the tank with Liquid Seal Assembly (LSA) 4
- Top of the tank with LSA 7 5
- Floating roof tank 2 6

FOR INSTALLATION ON

- In service tank 3 1
- New construction tank 2

PROCESS CONNECTION

- 1 1/2" BSP, CS socket 1
- 1 1/2" NPT, CS socket 2
- 1 1/2" ANSI Flanged, CS 3
- 1/2" ANSI Flanged, SS 304 4
- 1 1/2" ANSI Flanged, SS 316 5
- 1 1/2" ANSI A105 (forged flange) 6
- Others (Please Specify) 9

PIPING

- GI 3
- SS 304 4
- SS 316 6

CHECKER ASSEMBLY ⁴

- 0 No
- 1 Yes

BOTTOM ANCHOR

- 0 No bottom anchor 2
- 1 Welded CS
- 2 Welded SS 304
- 3 Welded SS 316
- 4 Weighted CS
- 5 Weighted SS 304
- 6 Weighted SS 316
- 7 By purchaser (In case of corrosive duties).

GUIDE WIRE TENSIONING ASSEMBLY

- 0 Not required
- 1 CS Cd (spring) + GI (cover)
- 2 SS 302 (spring) + SS 304 (cover)
- 3 SS 302 (spring) + SS 316 (cover)

GUIDE ROD AND COVER ASSEMBLY

(GUIDE RODS IN SS304 ARE INCLUDED IN THIS ASSEMBLY)

- 0 Not required
- 6 CS ANCHOR AND GI COVER
- 7 SS 304 ANCHOR AND COVER
- 8 SS 316 ANCHOR AND COVER

FLOAT DIAMETER & MATERIAL ⁵

- 0 Float not required 2
- 1 400 mm ϕ , SS304.
- 2 400 mm ϕ , SS316.
- 3 300 mm ϕ , SS304.
- 4 300 mm ϕ , SS316.
- 5 100 mm ϕ , SS304.
- 6 100 mm ϕ , SS316.

Note :

- 1 There is a minimum non measuring range of approximately 100 mm at the bottom and approximately 50 mm at the top of the tank. This is dependent on the tank shape.
- 2 In case of floating roof tanks, float cable of Open Scale Target Reading Type Level Indicator can be attached to the pontoon with a hook as shown in figure 2 below.
- 3 For retrofitting on existing tanks guide rod arrangement (upto 3 meters) & weighted guide wire anchor arrangement (above 3 meters) are recommended (Refer figure 10 & 11 on page 3 for mounting arrangements).
- 4 Use of checker (popularly known as pull chord or pull chain) is recommended when product is highly viscous or tends to solidify at ambient temperature. This arrangement consists of a nylon rope of length equal to (Tank height - 1.5) meters & a wooden handle.
- 5 A 300 mm ϕ float is supplied upto tank height less than 10 meters. A 400 mm ϕ float is recommended for tank heights more than 10 meters. A 100 mm ϕ float can be given for tank heights upto 3 meters. A perforated stilling pipe (150 NB) is essentially required for 100 mm ϕ float.
- 6 Float / piping / process connection in PP/ PVC is suitable for corrosive duties. For details refer LF-131-0802.
- 7 Refer figure no. 10 on page 3. The support structure is to be provided by the purchaser.
- 8 Refer figure no. 3 below. For details refer LF-131-0803. Volume indication can not be provided in this arrangement.

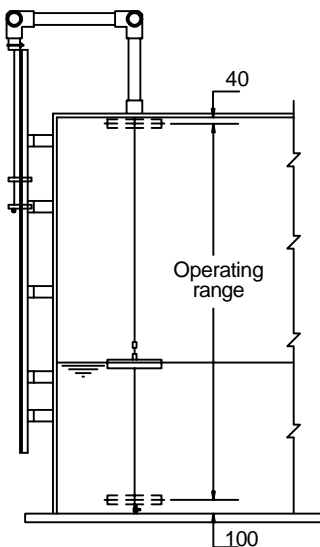

Figure no. 1
Operating Range ¹

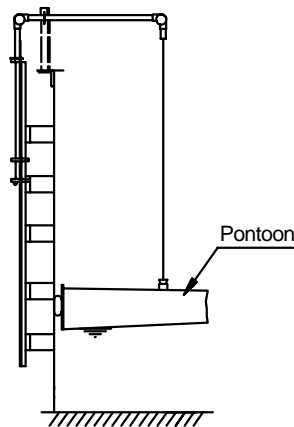

Figure no. 2
Mounting on Floating Roof Tank
with hook

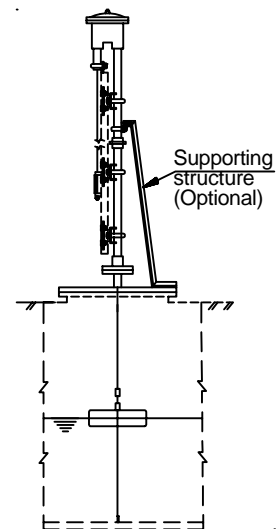

Figure no. 3
Top of Tank Mounting

MOUNTING ARRANGEMENTS

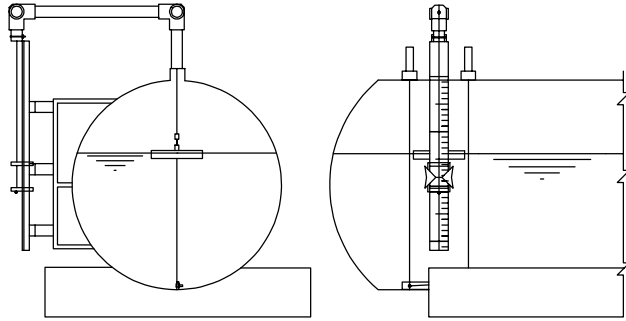

Fig. 4 Mounting for Horizontal Tank

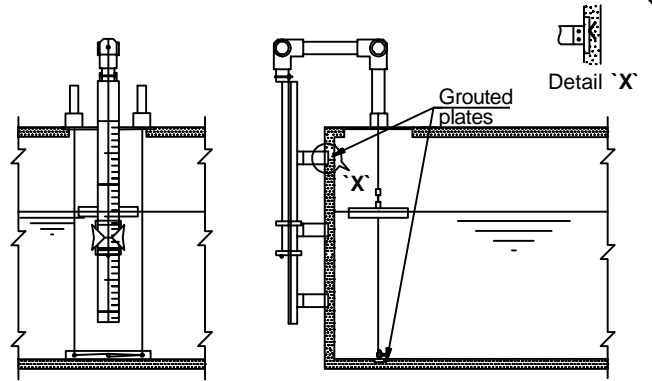

Fig. 5 Mounting for RCC Tank

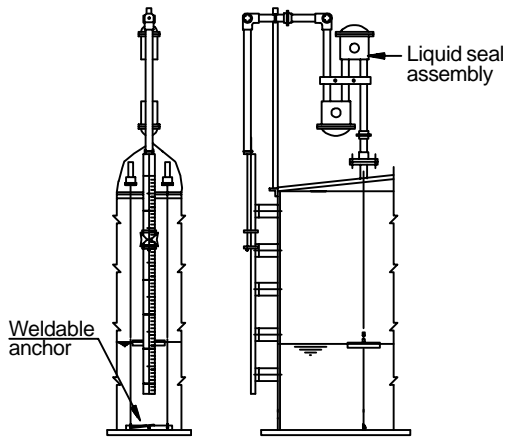

Fig. 6 Mounting with Liquid Seal Assembly

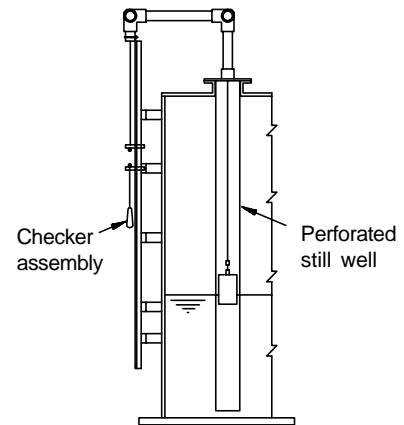

Fig. 7 Mounting with Stilling Pipe & Checker Assembly

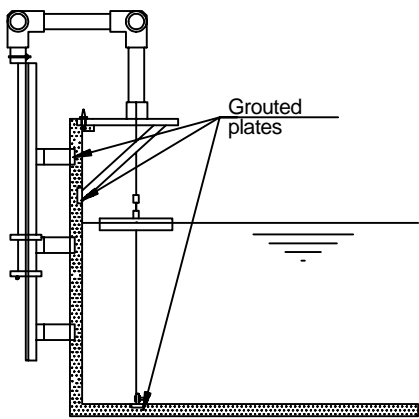

Fig. 8 Mounting on Open Tank

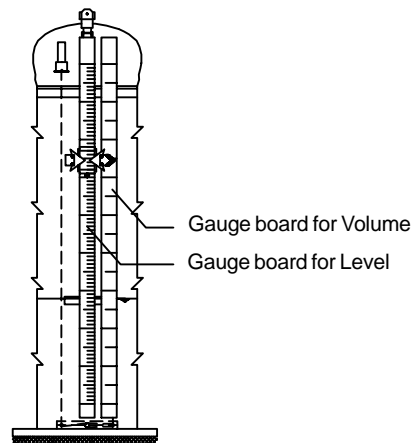

Fig. 9 Level + Volume Indication

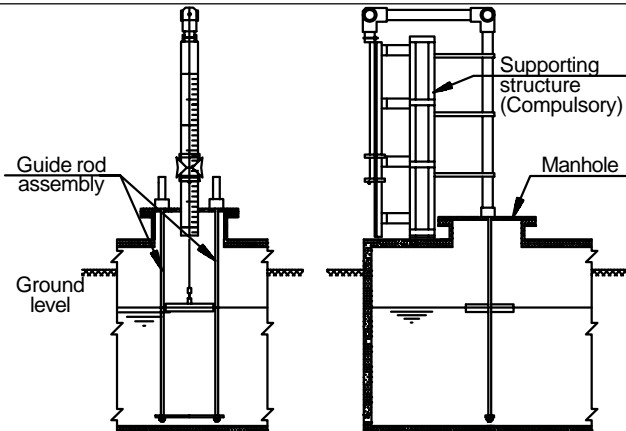

Fig. 10 Top of Tank Mounting with Guide Rod Assembly

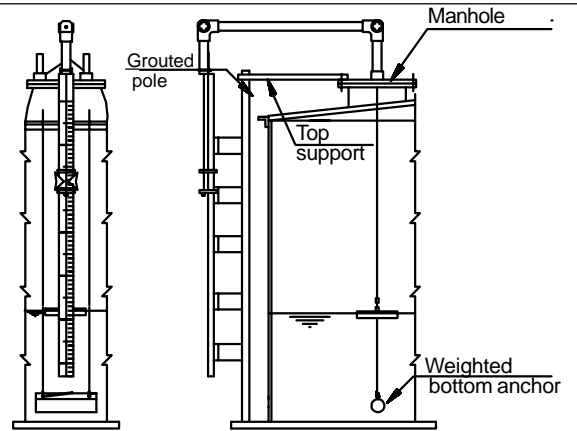

Fig. 11 Mounting with Weighted Guide wire Anchor (Tank in Service).

SPECIFICATIONS

- (1) Type : Float actuated target reading.
 (2) Range : Upto 20 meters (Depends on diameter of selected float).
 (3) Service : Clean and clear non corrosive liquids.
 (4) Resolution : 10 mm on the gauge board.
 (5) Markings : On the gauge board, minor markings at every 100 mm in black (40 mm high) and major markings at every 1000 mm in red (70 mm high).

(6) Floats	SIZE (mm)	GUIDED/UNGUIDED	USED FOR RANGE	ACCURACY (mm)
	φ 400	Guided	0 - 20 mtrs.	± 5
	φ 300	Guided	0 - 10 mtrs.	± 10
	φ 100	Unguided	0 - 3 mtrs.	± 25 (without liquid seal) ± 45 (with liquid seal)

- (7) Fittings : (a) Guide wire spring assembly with SS 316 guide wires - 2 Nos.
 (b) 90° elbow assembly in cast Aluminium polyurethane painted with SS316 pulley and teflon bush - 2 Nos.
 (c) Guide wire anchor (CS / SS304 / SS316) - 1 No.
 (d) Indicator assembly in Aluminium + SS with SS316 float cable - 1 No .
 (e) Aluminium polyurethane painted gauge boards { Total Gauge board length = (tank height + 200) mm } with mounting brackets and suitable hardware required as per tank height.
- (8) Optional : (a) Liquid seal assembly for 200 / 300 / 600 mm WC (water column) with transformer oil as sealant liquid and piping in GI (Optional piping in SS). For liquid seal aseembly, refer leaflet no. LF-133-0805 & LF-133-812.
 (b) Operation checker assembly with wooden handle and nylon rope.

- Note :
 1. Accuracy mentioned is at specific gravity equal to 1.
 2. For unguided 100 mm φ float, a perforated stilling pipe (150 NB min) must be provided to avoid float swinging.
 For such applications guide wires and bottom anchor are not required.

FITTINGS AND ACCESSORIES

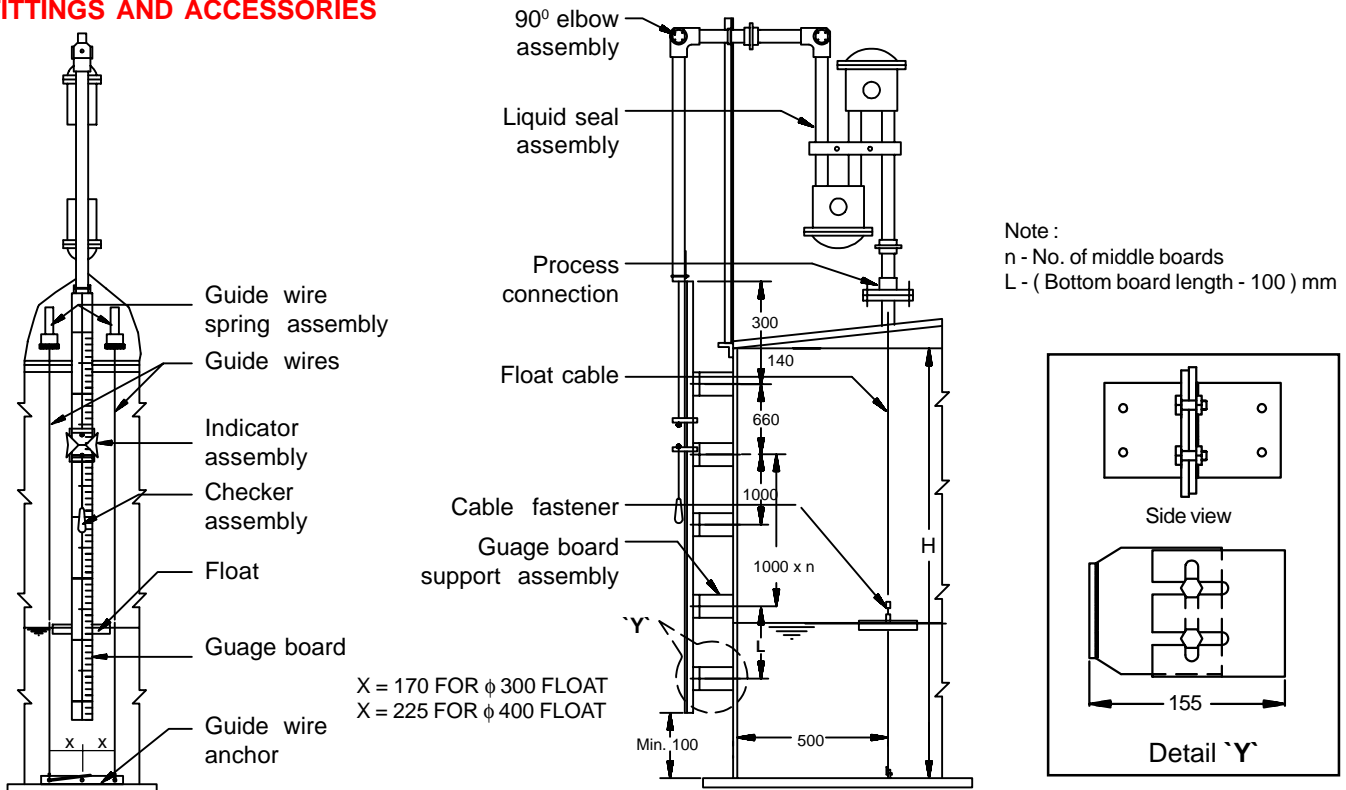

*** Continuous developments may necessitate changes without notice.

LF-131-0801 R10 (W) 03/2001

SBEM Pvt. Ltd.

39, Electronic Co-Operative Estate, Pune-Satara Road, Pune - 411 009 (INDIA)

Tel : 91-20-4220505, 4223375 Fax - 91-20-4215670

Email : sales@sbem.co.in sbemsales@vsnl.com

Web: www.sbem-india.com

Works : Bibwewadi Industrial Estate, 691/A/2, Pune-Satara Road, Pune-411 037(India)

Email : mfg@sbem.co.in

Office : MUMBAI

CHENNAI

NEW DELHI

VADODARA

Tele. : 91-22-2782 3601, 2782 3603

91-44-2445 1235, 2441 2947

91-11-2656 0647, 2696 9679

91-265-233 5196, 235 8184

Fax : 91-22-2782 3603

91-44-2441 2947

91-11-2696 9679

91-265-233 0906

Email : mumbai@sbem.co.in

chennai@sbem.co.in

newdelhi@sbem.co.in

vadodara@sbem.co.in