



Level Measurement & Control Solutions

GUIDED WAVE RADAR LEVEL TRANSMITTER

MICRO GUIDE 132 GWR (Non-Conductive Liquids)

INTRODUCTION

Guided Wave Radar, Micro Guide 132 GWR is designed for industrial use in continuous level measurement.

PRINCIPLE OF OPERATION

The SBEM Guided Wave Radar Level Transmitter Micro Guide 132 GWR operates on the technique of Time Domain Reflectometry. Pulses are transmitted along a probe or "wave guide". When the pulses reach the material surface they are reflected back to the sensor electronics. The reflection is due to the difference in the dielectric constants of air and the process medium which causes change in the characteristic impedance of the probe. The time-of-flight i.e., time between transmitted and reflected pulse is measured. This time is directly proportional to the distance from the point at which the sensor is mounted on the top of the vessel to the material surface (level). The output from the electronics is continuously updated as the level of the material surface changes.

APPLICATION

- ▶ Non-conductive liquids like Lubricating Oil/ Oil tanks

SPECIFICATIONS

Electrode	Rigid Concentric
Electrode Length	3 m max.
Electrode Diameter	Φ 40 mm
Electrode Material	SS 316
Accuracy	0.2% of Span
Display	Graphical
Housing	Cast Aluminium, Polyurethane painted, Dual Chamber, Weatherproof to IP-67
Process Temperature	0°C to 150°C
Ambient Temperature	70° C max.
Operating Pressure	≤ 10 Kg/cm ²
Output	4-20mA, HART, 2 Wire
Cable Entry	½" NPT
Process connection	Threaded 1 ½" BSP (std.)
Power Supply	28 VDC



FEATURES

- ▶ Echo suppression for False Echo.
- ▶ Insensitive to Vapours, Pressure, Foam & Density.
- ▶ HART compatible.
- ▶ Adjustability of measurement from 0 to 100 span or 0 to 50 %.
- ▶ Easy configuration & operation.
- ▶ Graphical display of echo curve.
- ▶ Dual chamber construction separates electronics from gland terminals.
- ▶ No moving parts.
- ▶ Electrodes for solids & conductive liquids also available- Refer LF-132 0802 & LF-132 0803

ORDER CODE :-

132 GWR- M 5 3 L D H 4 1 6 0 6 L =

Operating Conditions

M53 - 150°C, 10 Kg/cm²

Transmitter Configuration

L - Level measurement

Transmitter Housing

D - Al (2 Chamber)/ IP 67 Standard

Safety

H - Non Intrinsically safe

Output signal

A - 4 - 20 mA, 2 Wire

C - 4 - 20 mA, HART, 2 Wire

Electrode Code

41- Co-axial Ø25 mm

Electrode Material

6 - SS 316

Electrode Length (mm)

Up to 3000 mm max.

Cable Entry

N - 1/2" NPT

S- 3 Pin Plug Metallic Receptor Connector

Material of slip on flange

0 - Not applicable

2 - CS

4 - SS 304

6 - SS 316

Process Connection

GP - Threaded 1 1/2" BSP

NP - Threaded 1 1/2" NPT

XX - Slip on flange * (Refer Flange Table)

Material of outer pipe

6 - SS 316

Electrode sheathing

0 - Not applicable

* FLANGE TABLE :-

Pressure Rating:

150# (~10Kg/cm²)

Size	ANSI
1"	11
1 1/2"	16
2"	21
2 1/2"	26
3"	31
4"	41
5"	51
6"	61

MECHANICAL DIMENSIONS :-

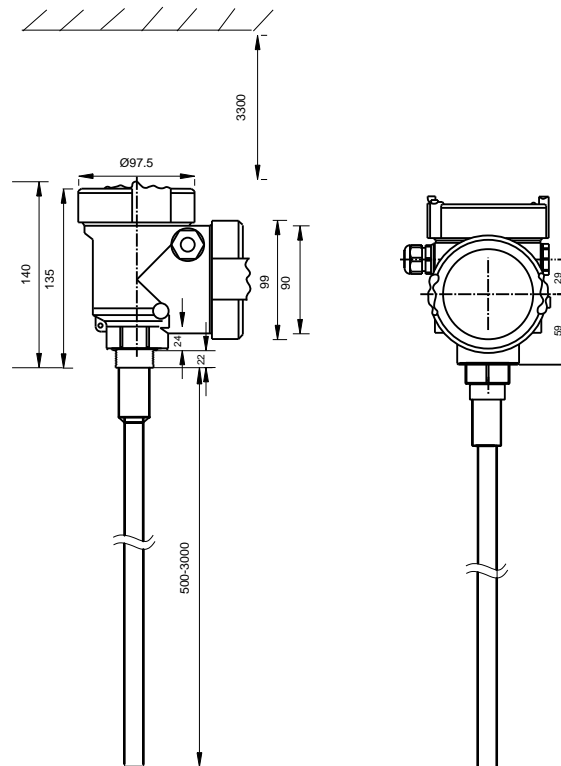

*** Continuous developments may necessitate changes without notice.

LF-132-0801 R01 10/2010

LF_GuideWvRdr_132GWR



SBEM Pvt. Ltd.

H.O. : 39, Electronic Co-Operative Estate, Pune - 411 009 (India)
 Tel. : 91-20-41030100, 24220505, 24223375 Fax : 91-20-24215670
 Email : sales@sbem.co.in, ho@sbem.co.in

Web : www.sbem-india.com



ISO 9001: 2008

Works : Bibwewadi Industrial Estate, 691/A/2, Pune-Satara Road, Pune - 411 037 (India)

Office : Mumbai
 Tel. : 91-22-27823601 / 03
 Fax : 91-22-27823603
 Email : sbemho@bom4.vsnl.net.in
 mumbai@sbem.co.in

Chennai
 91-44-24481235, 24486947
 91-44-24486947
 chennai@sbem.co.in

New Delhi
 91-11-26560647, 26969679
 91-11-26969679
 newdelhi@sbem.co.in

Pune & Gujarat
 91-20-41030100,
 91-20-24215670
 pune@sbem.co.in
 gujarat@sbem.co.in