



NEW PRODUCT RELEASE

Z' TYPE EXTENSION FOR MAGNETIC FLOAT SWITCH, SERIES 137.

`Z' type is newly introduced extension to be used for our field proven side mounted Magnetic Float Switch, Series 137. This is practically a horizontal extension with fixed length and offset. All other specifications are as our standard 137. Wetted parts are in SS 316 only. This is applicable to all switch and flange modules except PNP and High Temperature Stand Off. These are intended towards following applications.

- Offset switching point, i.e. level control is not in line of switch mounting nozzle.
- Floating particles or slurry application which may obstruct swiveling of float and extension around pivot point in case of standard `H' type of extension.

ORDERING CODE

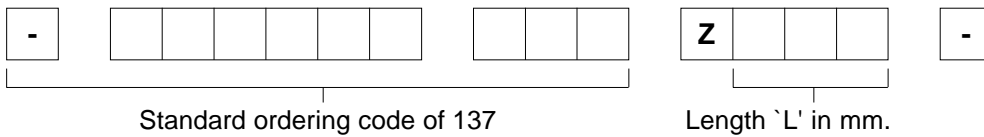

DIMENSIONS

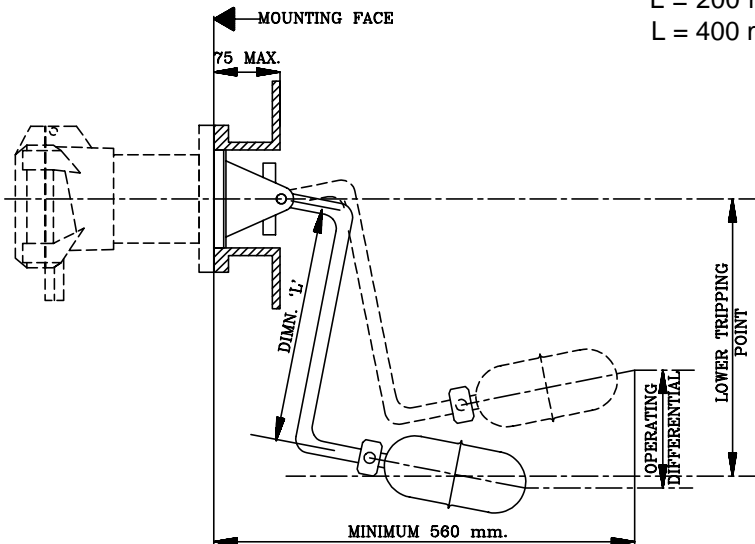

Length `L' in mm.
 L = 100 mm.
 L = 200 mm.
 L = 400 mm.

Table for "Operating differential (OD)" and "Lower trip point (LTP)"

Extension (Dimension `L')	Liquid specific gravity					
	0.8		0.9		1.0	
	OD	LTP	OD	LTP	OD	LTP
100	29	97	35	106	41	116
200	31	180	38	196	45	216
300	34	263	43	286	49	315

All dimensions are in mm.

*** Continuous development may necessitate changes without notice.

LF-137-0806 R01 03/99



SBEM Pvt. Ltd.

39, Electronic Co-Operative Estate, Pune-Satara Road, Pune - 411 009 (INDIA)

Tel. - 91-20-4220505, 4223375 Fax - 91-20-4215670

Email - sbemsales@sbem.co.in, sbemsales@vsnl.com

Works : Bibwewadi Industrial Estate, 691/A/2, Pune-Satara Road, Pune-411 037(India) Email : mfg@sbem.co.in

Office : **MUMBAI**

Tele. : 91-22-5222824, 5242520

Fax : 91-22-5230236

Email : mumbai@sbem.co.in

Office : **CHENNAI**

91-44-4452235, 4412947

91-44-4412947

chennai@sbem.co.in

Office : **NEW DELHI**

91-11-6560647, 6969679

91-11-6969679

newdelhi@sbem.co.in