



Gauge Adapter Unit - GAU

APPLICATIONS

The GAUGE ADAPTER UNIT (GAU) permits integration of SBEM gauges into the SAAB Gauging System. This unit collects data from SBEM tank gauging devices and interfaces to SAAB Tank Radar Level (TRL) gauging system through Field Communication Unit (FCU). GAU Frequency Shift Keying (FSK) modem is compatible to TRL / 2 physical layer and data link layer. The output is in modbus RTU format.

ENCLOSURE

The GAU unit has a sheet steel, powder-coated enclosure. The unit can be mounted on wall or inside of panel in a control room.

FEATURES

- High Reliability and Extended Life
- Low Cost
- No maintenance
- Local display for configuration (optional)

SPECIFICATIONS

Power : 110 / 230 VAC ±15%, 50Hz, 2VA

Field Devices : Smart Tank Data Transmitter (133-STDT) / Servo Gauge 139-SG / Hybrid Servo Gauge / LPG Servo Gauge

Output Port :

- ◆ Communication : Serial
FSK modem for communication between GAU_S & Saab FCU compatible to TRL / 2 physical layer.
- ◆ Baud rates : selectable 1200/ 2400/ 4800/ 9600
- ◆ Data protection : Cyclic Redundancy check (CRC)
- ◆ Protocol : RTU Modbus, registers compatible to Saab RTG + DAU

Protection :

- ◆ Output Galvanically isolated.
- ◆ Surge protection using Metal Oxide Varistors.

Environment :

- ◆ Operating temperature 0 to 55°C.
- ◆ Relative humidity 95% max., Non-Condensing
- ◆ Storage temperature: -40 to 85°C

Mounting : Wall / panel (inside) safe area mounting.



SPECIFICATIONS (Cont.)

Construction : Sheet Steel Powder coated enclosure

Terminations :
Suitable for 2.5mm² conductor cable

Cabling :

- From ITU in control Room : 2 core X 1 mm² Copper conductor cable PVC insulated.

- From Signal Junction Box (JBS) in field : 1 pair X 1mm². Twisted pair shielded copper, PVC insulated armored cable.

Input Port : 1/2/3/4 ports

- ◆ Communication : Serial port
- ◆ Type : EIA RS 485, Half Duplex, No Handshaking.
- ◆ Baud Rate : 1200/ 2400/ 4800/ 9600
- ◆ Protocol : SBEM proprietary.
- ◆ Data Protection : longitudinal parity check & vertical checksum
- ◆ No. of tanks : Max. 64 tanks –16 field devices on each port

ORDERING INFORMATION:

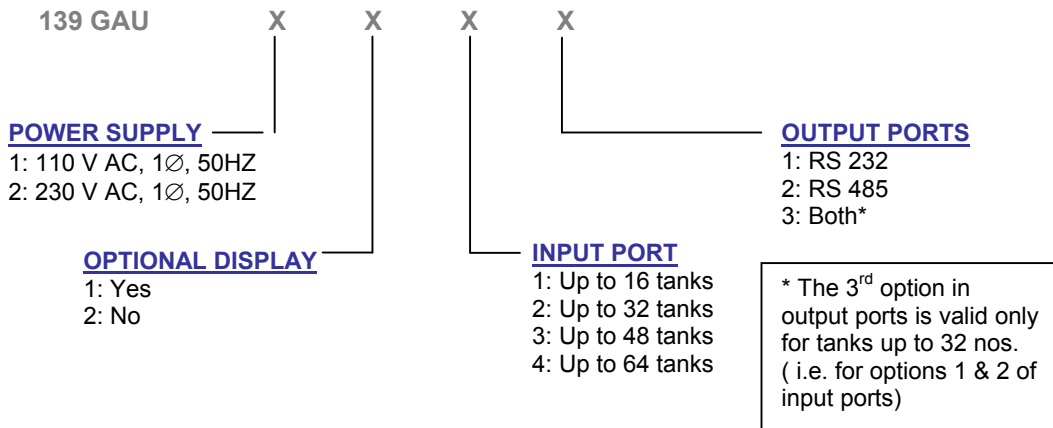

ORDERING EXAMPLE: 139 GAU 2 1 2 3

Gauge Adapter Unit with 230V AC, single phase, 50 Hz power supply, with display in it, with 2 input ports i.e. for 32 tanks and both output ports – RS 232 & RS 485.

GENERAL ARRANGEMENT

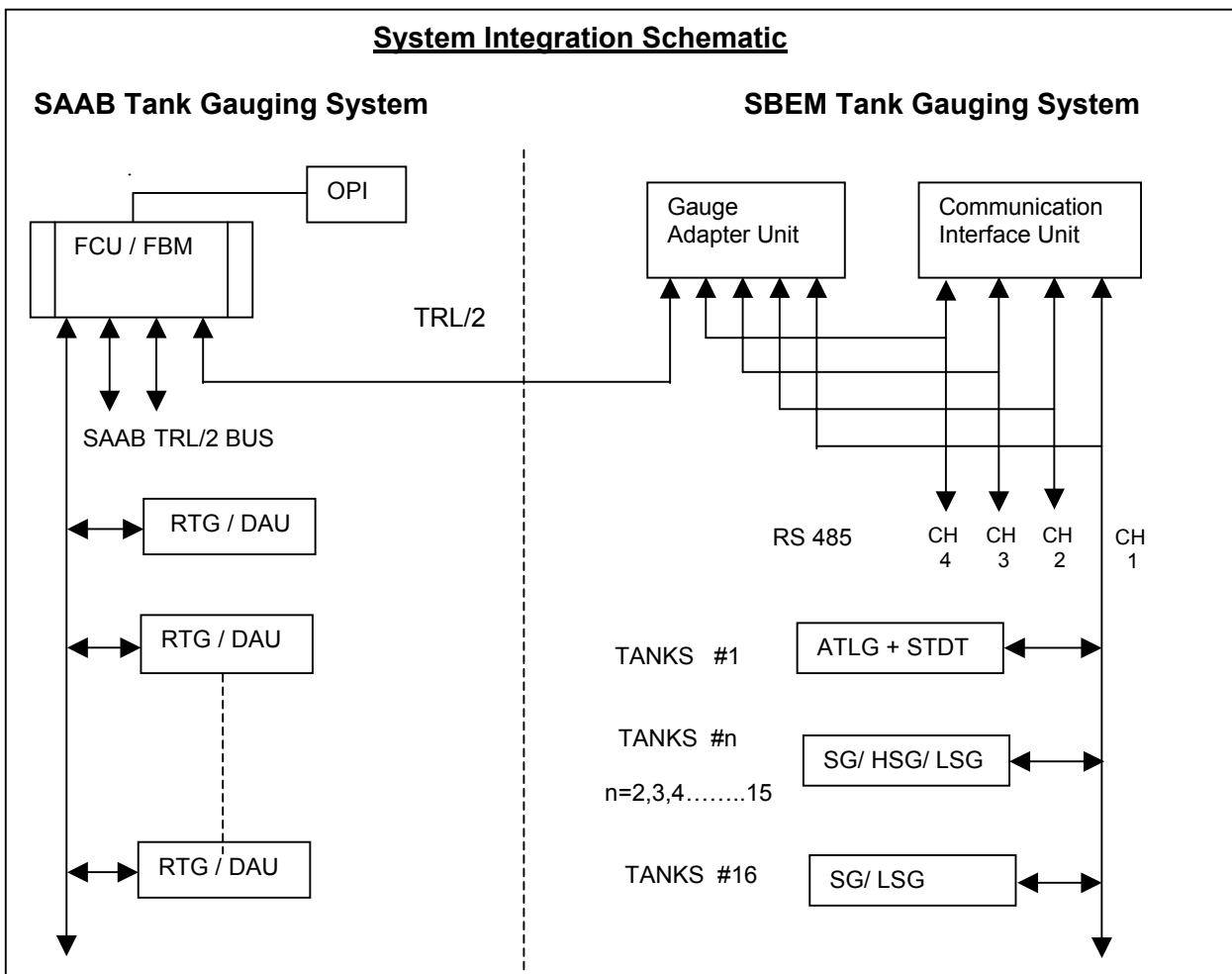

*** Continuous developments may necessitate various changes without prior notice.

LF-139-0820 R0 (W) 11/2002



SBEM Pvt. Ltd.

39, Electronic Co-Operative Estate, Pune-Satara Road, Pune – 411 009 (INDIA)

Tel.: 91-20-4220505, 4223375 Fax – 91-20-4215670

Email: sales@sbem.co.in, sbemsales@vsnl.com, Web: www.sbem-india.com



Works:	Bibwewadi Industrial Estate, 691/A/2, Pune-Satara Road, Pune-411 037(India)	Email:	mfq@sbem.co.in
Office	MUMBAI	CHENNAI	NEW DELHI
Tele.	91-22-2782 3601, 2782 3603	91-44-2445 1235, 2441 2947	91-11-2656 0647, 2696 9679
Fax	91-22-2782 3603	91-44-2441 2947	91-11-2696 9679
Fmail	mumbai@sbem.co.in	chennai@sbem.co.in	newdelhi@sbem.co.in
		VADODARA	
		91-265-233 5196, 235 8184	
		91-265-233 0906	
		vadodara@sbem.co.in	