



Calibration Chamber, 139-CC

INTRODUCTION

The Calibration Chamber is used to connect Servo Gauge to stilling well in case of non-pressurized tanks or to isolation ball valve in case of pressurized applications. It provides a fixed reference for calibration of the Servo Gauge. A mechanical stopper fitted at the top end within the calibration chamber achieves this

Removing the side flange of the calibration chamber can access the displacer of Servo Gauge. A glass window is provided on the side flange for visual reference only for 6 kg/cm² versions. Offset calibration chamber can be provided to match Servo gauge to smaller size stilling well. Suitable spool piece can be used to match the calibration chamber to various sizes of stilling wells.

ACCESSORIES

Following Accessories are suggested for Calibration Chambers used for pressurized applications:

1. Weatherproof Pressure gauge 100mm dial, Range 0-60 kg/cm²
2. 1/4" Stainless steel Needle valve to de-pressurize the Calibration Chamber after closing the ball valve



Servo Gauge fitted on High Pressure Calibration Chamber



Calibration Chamber for Low Pressure Applications

ORDERING INFORMATION

MODEL

139-CC-CALIBRATION CHAMBER FOR SERVO GAUGE 139

<table border="0"> <tr> <td style="border-right: 1px solid black; padding-right: 5px;">139CC</td> <td style="border-right: 1px solid black; padding-right: 5px;">2</td> <td style="border-right: 1px solid black; padding-right: 5px;">2</td> <td style="border-right: 1px solid black; padding-right: 5px;">2</td> <td style="border-right: 1px solid black; padding-right: 5px;">2</td> <td style="padding-left: 20px;">Typical Model No.</td> </tr> </table>	139CC	2	2	2	2	Typical Model No.	<table border="0"> <tr> <td style="border-right: 1px solid black; padding-right: 5px;">CODE</td> <td style="border-right: 1px solid black; padding-right: 5px;">MATERIAL OF CONSTRUCTION</td> <td></td> <td></td> <td></td> <td></td> </tr> <tr> <td style="border-right: 1px solid black; padding-right: 5px;">1.</td> <td style="border-right: 1px solid black; padding-right: 5px;">Cast Aluminium LM-6 (up to 6 kg /cm²)</td> <td></td> <td></td> <td></td> <td></td> </tr> <tr> <td style="border-right: 1px solid black; padding-right: 5px;">2.</td> <td style="border-right: 1px solid black; padding-right: 5px;">Carbon Steel (ASTM A-105)</td> <td></td> <td></td> <td></td> <td></td> </tr> <tr> <td style="border-right: 1px solid black; padding-right: 5px;">3.</td> <td style="border-right: 1px solid black; padding-right: 5px;">SS 304 (ASTM A-182-F304)</td> <td></td> <td></td> <td></td> <td></td> </tr> <tr> <td style="border-right: 1px solid black; padding-right: 5px;">4.</td> <td style="border-right: 1px solid black; padding-right: 5px;">SS 316 (ASTM A-182-F-316)</td> <td></td> <td></td> <td></td> <td></td> </tr> <tr> <td style="border-right: 1px solid black; padding-right: 5px;">CODE</td> <td style="border-right: 1px solid black; padding-right: 5px;">OPERATING PRESSURE</td> <td></td> <td></td> <td></td> <td></td> </tr> <tr> <td style="border-right: 1px solid black; padding-right: 5px;">1.</td> <td style="border-right: 1px solid black; padding-right: 5px;">0 – 6 kg/sq.cm</td> <td></td> <td></td> <td></td> <td></td> </tr> <tr> <td style="border-right: 1px solid black; padding-right: 5px;">2.</td> <td style="border-right: 1px solid black; padding-right: 5px;">0 – 30 kg/sq.cm</td> <td></td> <td></td> <td></td> <td></td> </tr> <tr> <td style="border-right: 1px solid black; padding-right: 5px;">CODE</td> <td style="border-right: 1px solid black; padding-right: 5px;">BOTTOM FLANGE SIZE</td> <td></td> <td></td> <td></td> <td></td> </tr> <tr> <td style="border-right: 1px solid black; padding-right: 5px;"></td> <td style="border-right: 1px solid black; padding-right: 5px;">(top flange 2" ANSI)</td> <td></td> <td></td> <td></td> <td></td> </tr> <tr> <td style="border-right: 1px solid black; padding-right: 5px;">1.</td> <td style="border-right: 1px solid black; padding-right: 5px;">4"</td> <td></td> <td></td> <td></td> <td></td> </tr> <tr> <td style="border-right: 1px solid black; padding-right: 5px;">2.</td> <td style="border-right: 1px solid black; padding-right: 5px;">6"</td> <td></td> <td></td> <td></td> <td></td> </tr> <tr> <td style="border-right: 1px solid black; padding-right: 5px;">3.</td> <td style="border-right: 1px solid black; padding-right: 5px;">8"</td> <td></td> <td></td> <td></td> <td></td> </tr> <tr> <td style="border-right: 1px solid black; padding-right: 5px;">CODE</td> <td style="border-right: 1px solid black; padding-right: 5px;">PRESSURE RATING</td> <td></td> <td></td> <td></td> <td></td> </tr> <tr> <td style="border-right: 1px solid black; padding-right: 5px;">1</td> <td style="border-right: 1px solid black; padding-right: 5px;">150 lbs</td> <td></td> <td></td> <td></td> <td></td> </tr> <tr> <td style="border-right: 1px solid black; padding-right: 5px;">2</td> <td style="border-right: 1px solid black; padding-right: 5px;">300 lbs</td> <td></td> <td></td> <td></td> <td></td> </tr> </table>	CODE	MATERIAL OF CONSTRUCTION					1.	Cast Aluminium LM-6 (up to 6 kg /cm ²)					2.	Carbon Steel (ASTM A-105)					3.	SS 304 (ASTM A-182-F304)					4.	SS 316 (ASTM A-182-F-316)					CODE	OPERATING PRESSURE					1.	0 – 6 kg/sq.cm					2.	0 – 30 kg/sq.cm					CODE	BOTTOM FLANGE SIZE						(top flange 2" ANSI)					1.	4"					2.	6"					3.	8"					CODE	PRESSURE RATING					1	150 lbs					2	300 lbs				
139CC	2	2	2	2	Typical Model No.																																																																																																		
CODE	MATERIAL OF CONSTRUCTION																																																																																																						
1.	Cast Aluminium LM-6 (up to 6 kg /cm ²)																																																																																																						
2.	Carbon Steel (ASTM A-105)																																																																																																						
3.	SS 304 (ASTM A-182-F304)																																																																																																						
4.	SS 316 (ASTM A-182-F-316)																																																																																																						
CODE	OPERATING PRESSURE																																																																																																						
1.	0 – 6 kg/sq.cm																																																																																																						
2.	0 – 30 kg/sq.cm																																																																																																						
CODE	BOTTOM FLANGE SIZE																																																																																																						
	(top flange 2" ANSI)																																																																																																						
1.	4"																																																																																																						
2.	6"																																																																																																						
3.	8"																																																																																																						
CODE	PRESSURE RATING																																																																																																						
1	150 lbs																																																																																																						
2	300 lbs																																																																																																						

Tank Accessory Selection Table for Pressurized & Non-Pressurized Applications

Tank Accessory	Tank Height	DISPLACER DIAMETER		
		Dia 45mm	Dia 65mm	Dia 90mm
Calibration Chamber	6m	4"	4"	6"
		Concentric	Eccentric	Concentric
		6"	6"	6"
	16m	4"	4"	6"
		Concentric	Eccentric	Concentric
		6"	6"	6"
	27m	4"	4"	6"
		Concentric	Eccentric	Concentric
		6"	6"	8"
Ball Valve	6m	4"	4"	4"
	16m	4"	4"	6"
	27m	4"	4"	6"
Adaptor	6m	-	-	-
	16m	-	4" - 6"	-
	27m	4" - 6"	4" - 6"	4" - 6"
Stilling Well	6m	4" NB	4" NB	6" NB
		6" NB	6" NB	6" NB
	16m	4" NB	6" NB	6" NB
		6" NB	6" NB	6" NB
	27m	6" NB	8" NB	8" NB

Pressure	Flange Type		Material of Construction				Pressure Rating	
	RF	FF	Cast Al.	SS 304	SS 316	C S	150 Lbs	300 Lbs
Low 0 – 06 kg / cm ²	✓	✓	✓	X	X	X	✓	X
High 0 – 30 kg / cm ²	✓	X	X	✓	✓	✓	X	✓

NOTES

- Select Displacer diameter from Selection table
- Stilling-well sizes chosen are of minimum size. Higher sizes can be chosen
- Adjust Adaptor / Stilling well height to get display of Servo Gauge at eye level (1.5m)
- **Pressurized applications are shown in RED**
- **Non-Pressurized / Low Pressure applications are shown in BLUE**

MECHANICAL DIMENSIONS:

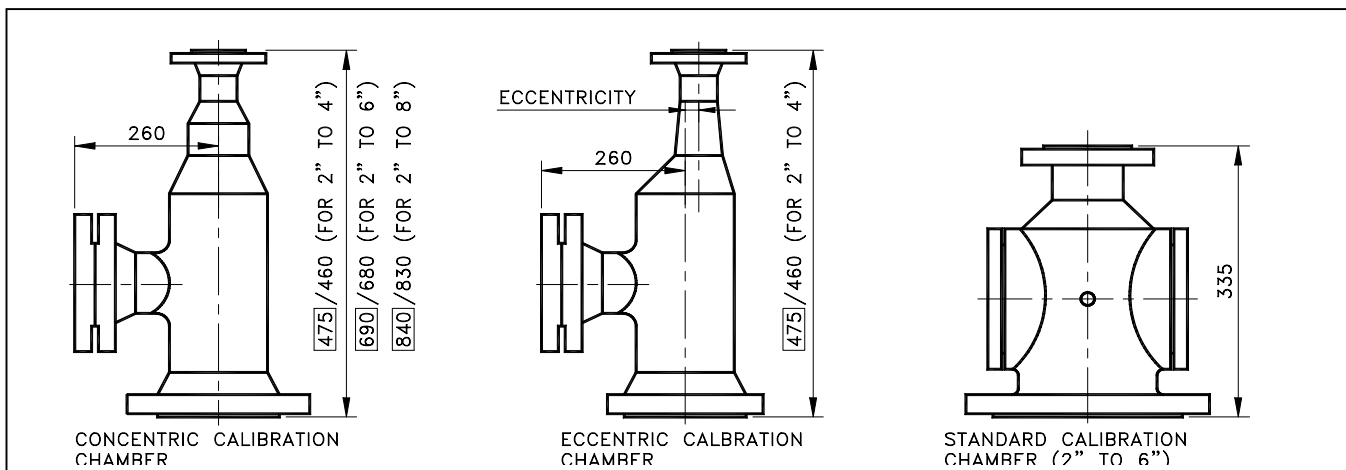

Continuous developments may necessitate changes in specifications without notice

LF-139-0805 R03 (W) 03/2003



SBEM Pvt. Ltd.

39, Electronic Co-Operative Estate, Pune-Satara Road, Pune – 411 009 (INDIA)

Tel.: 91-20-4220505, 4223375 Fax – 91-20-4215670

Email: sales@sbem.co.in, sbemsales@vsnl.com, Web: www.sbem-india.com



Works: Bibwewadi Industrial Estate, 691/A/2, Pune-Satara Road, Pune-411 037(India) Email: mfg@sbem.co.in

Office MUMBAI

Tele. 91-22-2782 3601, 2782 3603

Fax 91-22-2782 3603

E-mail mumbai@sbem.co.in

CHENNAI

91-44-2445 1235, 2441 2947

91-44-2441 2947

chennai@sbem.co.in

NEW DELHI

91-11-2656 0647, 2696 9679

91-11-2696 9679

newdelhi@sbem.co.in

VADODARA

91-265-233 5196, 235 8184

91-265-233 0906

vadodara@sbem.co.in